

Unilift KP



TM01 7145 4099

The Unilift KP pump is designed for liquid transfer and drainage of clean or slightly dirty wastewater with the pump completely or partly submerged in the liquid.

The pump is suitable for these applications:

- drainage of cellars or buildings
- pumping of domestic wastewater without toilet waste
- groundwater lowering
- emptying applications, e.g. in pools, tanks and vessels
- pumping applications within agriculture, the dairy industry, horticulture and the process industry.

Approvals

VDE, LGA, UL and CSA.

Pumped liquids

Pumps without level switch or with float switch

The pumps are suitable for these liquids:

- clean, non-aggressive water
- slightly dirty (grey) wastewater.

If the pump has been used for other liquids than clean water, it should be flushed through with clean water immediately after use. The open-impeller construction ensures a free passage of solids up to a diameter of $\varnothing 10$ mm.

Pumps with vertical level switch

The pumps must only be used for the pumping of clean groundwater and drain water.

Operating conditions

Installation depth: Max. 10 m below liquid level
 Min. liquid temperature: 0°C
 Max. liquid temperature at continuous operation: 50°C

During continuous pumping, the suction strainer must always be completely covered by the liquid.

Max. liquid temperature: 70°C for periods not exceeding two minutes at intervals of at least 30 minutes.

Discharge

Unilift KP 150, KP 250 and KP 350: Rp 1¼.

Pump sleeve and housing

Single-stage, submersible, stainless steel, drainage pump in a robust design with upward-pointing discharge port placed on top of the pump.

The water enters the pump through the holes of the suction strainer, preventing the passage of large solids. The sturdy impeller has single-curved vanes with bevelled front edges preventing fibres from jamming the impeller. The guide vanes in the pump housing guide the liquid, lifting sand grains into the liquid flow, thus preventing blocking by sand.

The outer casing is made in one piece. The mains cable and the cable of the level switch are combined in one vulcanized and water-tight plug, which is secured to the socket of the hermetically sealed stator housing.

Motor

The motor is a single- or three-phase asynchronous canned motor with liquid-filled rotor chamber and water-lubricated bearings. The motor is cooled by the pumped liquid around the motor.

Enclosure class: IP 68

Insulation class: F.

The motor incorporates automatic overload protection which cuts out the motor in case of overload. When cooled to normal temperature, the motor restarts automatically.

Materials

Component	Material	DIN W.-Nr.	AISI
Outer casing	Stainless steel	1.4301	304
Pump housing	Stainless steel	1.4301	304
Suction strainer	Stainless steel	1.4301	304
Impeller	Stainless steel	1.4301	304
Shaft	Stainless steel	1.4057	431
Stator housing	Stainless steel	1.4301	304
Guide vanes	Stainless steel	1.4301	304
Bearings	Carbon		
O-rings	NBR		
Seal rings			
Cables	H 07 RN-F		

Selection

The below overview is suitable for the selection of the correct size of Unilift KP pumps used in stationary applications.

The flow velocity through the discharge pipe must be minimum 0.7 m/s to ensure self-cleaning. Example: A DN 32 discharge pipe with an inner diameter of 26 to 34 mm (depending on local standards) requires a minimum flow velocity of approximately 2.3 m³/h.

The overview below shows the maximum lengths of combined vertical and horizontal DN 32 discharge pipes.

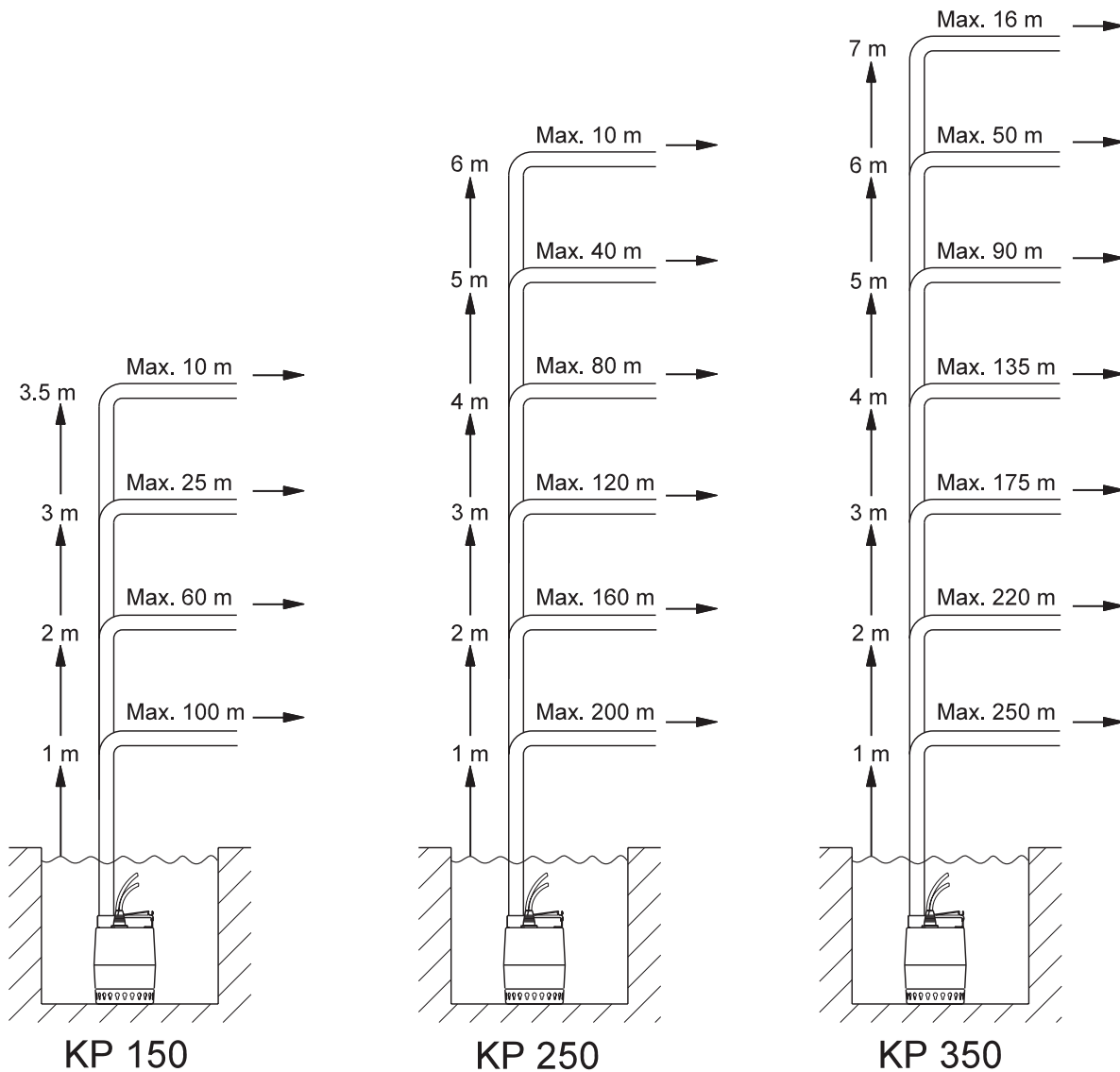

TMM03 1643 2505

The above overview is only intended as a guide. Grundfos is not liable for any faulty installations based on the overview.

Note: If the non-return valve is used, the pressure drop in the valve is 0.2 m head, which is to be subtracted from the vertical pipe lengths.

The vertical height of the discharge pipe should be measured from the pump stop level.

Performance curves

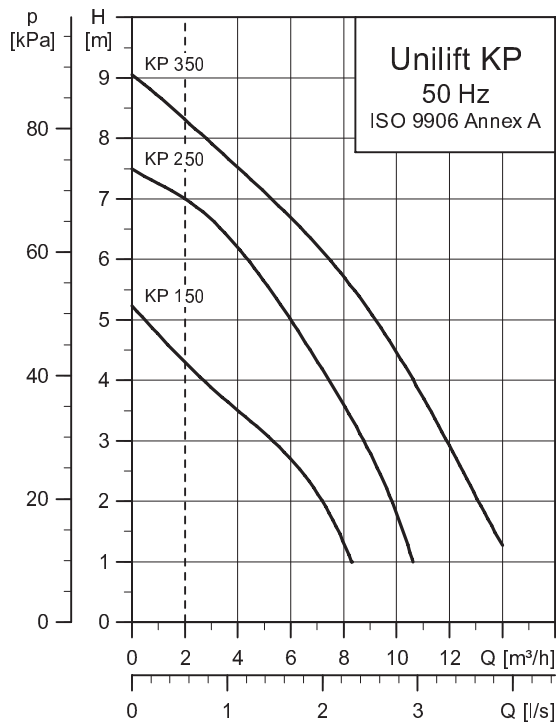

The broken line represents a min. liquid velocity of 0.7 m/s with a DN 32 discharge pipe to DIN EN 12056.

TM03 1583 2505

Pump type	Voltage [V]	P ₁ [W]	I _n [A]	Dimensions [mm]						Weight [kg]
				H	B1	B2	L1	L2	L3	
Unilift KP 150	1 x 220-230	300	1.3	225	149	31	350	400	70	6.3
Unilift KP 150	1 x 230-240	300	1.3	225	149	31	350	400	70	6.3
Unilift KP 250	1 x 220-230	480	2.3	225	149	31	350	400	70	7.2
Unilift KP 250	1 x 230-240	480	2.2	225	149	31	350	400	70	7.2
Unilift KP 250	3 x 380-415	480	0.8	225	149	31	350	400	70	7.2
Unilift KP 350	1 x 220-240	700	3.2	235	149	31	350	410	70	8.0
Unilift KP 350	3 x 380-400	700	1.3	235	149	31	350	410	70	8.0

With float switch

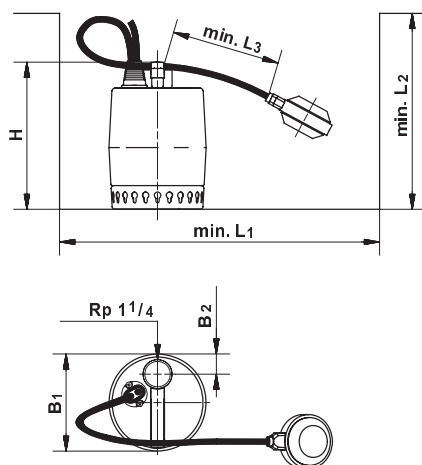

TM00 1803 1597

With vertical level switch

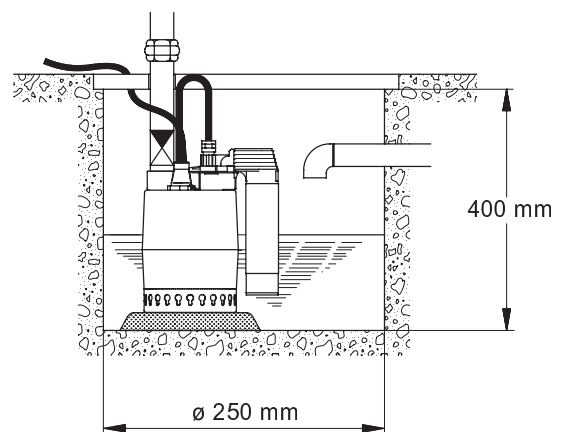

TM01 1109 1098

Installation

Pumps without level switch or with float switch can be used in vertical position with the discharge port uppermost or in horizontal or tilted position with the discharge port as the highest point of the pump.

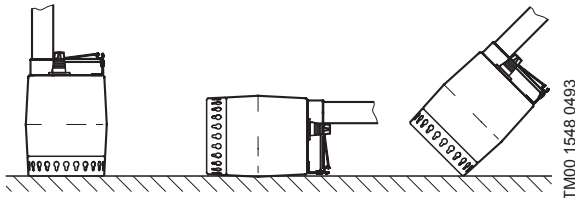

Pumps with vertical level switch must be used in the vertical position.

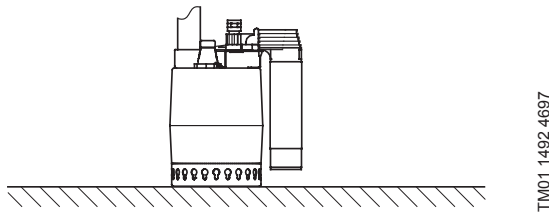

The Unilift KP pump with vertical level switch is well suited for permanent installation.

Level switches

A level switch, which gives impulses to start/stop between two levels of liquid, is connected to pumps intended for automatic operation. This type of installation requires a non-return valve in the discharge pipe or pump. The pumps are available with two different types of level switches.

Minimum liquid level

- manual operation: 14 mm
- automatic operation: See below.

Pumps with float switch

A clamp on the handle of the pump holds the cable of the level switch. The difference in level between start and stop can be adjusted by changing the free cable length between the handle of the pump and the level switch.

Dimensions for Unilift KP 350 are marked with an "★".

Float switch

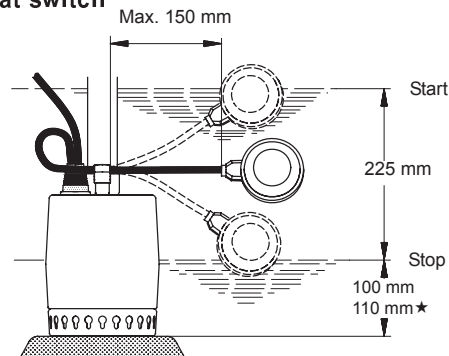

Pumps with vertical level switch

For pumps with vertical level switch, the difference in level between start and stop is not adjustable.

Dimensions for Unilift KP 350 are marked with an "★".

Vertical level switch

