

CIRCULATORS FOR DOMESTIC HOT WATER SYSTEMS



GENERAL DATA

Applications

Pump for hot water circulation in domestic central heating and air conditioning systems of the closed circuit pressurized type or open circuit type.

Construction features

Enbloc body composed of hydraulic section in bronze and wet rotor motor. Motor casing in die cast aluminium. Impeller in technopolymer. Motor shaft in hardened stainless steel held in graphite bearings lubricated by the pumping medium.

Rotor protective jacket, stator jacket, and closing flange in stainless steel.

Ceramic thrust ring, silicone seals and brass air breather plug. The two-pole asynchronous wet-rotor motor is resistance protected and does not require any form of overload protection.

Three-speed operation.

Protection rating: IP 44

Insulation class: F

Cable gland: PG 11

Installation: with horizontal motor shaft.

Standard voltage input: single-phase 230 V / 50 Hz

Special versions on request - alternative voltages and/or frequencies

CIRCULATORS FOR DOMESTIC HOT WATER SYSTEMS

TECHNICAL DATA

No.	PARTS	MATERIALS
1	PUMP BODY	BRONZE
4	IMPELLER	TECHNOPOLYMER
7A	MOTOR SHAFT	CERAMIC
7B	ROTOR	-
8	STATOR	-
9	CAPACITOR	-
10	MOTOR CASING	DIE CAST ALUMINIUM
11	BREATHER PLUG	BRASS
100	TERMINAL BOX	-
127	SEAL RING	ETHYLENE POLYPROPYLENE
128	STATOR JACKET	STAINLESS STEEL
129	ROTOR JACKET	STAINLESS STEEL
130	CLOSING FLANGE	STAINLESS STEEL
131	THRUST RING SUPPORT	ETHYLENE POLYPROPYLENE
132	BUSHINGS	GRAPHITE
133	THRUST RING	CERAMIC

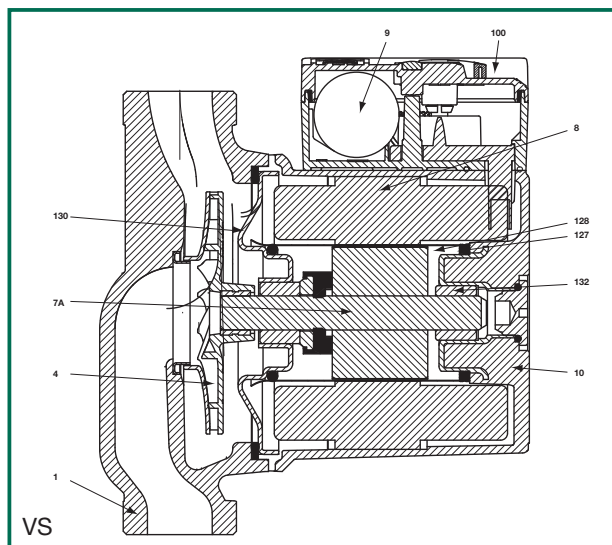

- Designation index:
(example)

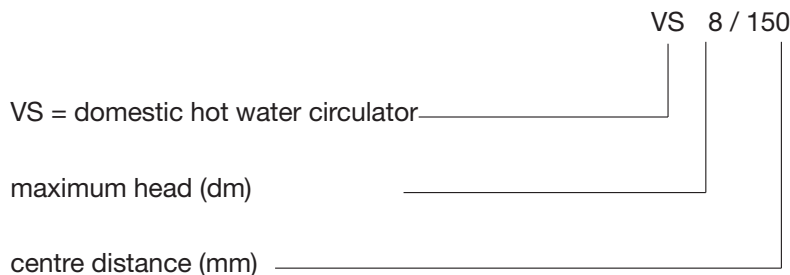

Operating range:

from 0.6 to 3.7 m³/h with head of up to 6 m.

Liquid temperature range:

from -10°C to +85°C for DHW applications and +110°C for other uses
To avoid the formation of lime scale avoid exceeding 65°C and
install an anti-scale system when water hardness exceeds 15°f.

Liquid quality requirements:

clean, free of solid contaminants and mineral oils, non-viscous,
chemically neutral, close to the properties of water
(max. glycol contents 30%).

Maximum working pressure:

10 bar (1000 kPa).

Minimum suction pressure:

the values are given in the relative tables.

Installation:

with HORIZONTAL MOTOR SHAFT

Special executions on request:

alternative voltages and/or frequencies

Accessories:

1/2"F - 3/4"F - 1"F unions
solder unions for copper pipes:

Ø 22 mm
Ø 28 mm

The performance curves are based on kinematic viscosity values = 1 mm²/s and density equivalent to 1000 kg/m³. Tolerance of curves to ISO 9906.

CIRCULATORS FOR DOMESTIC HOT WATER SYSTEMS

Liquid temperature range: from -10°C to +85°C
 Maximum working pressure: 10 bar (1000 kPa)

VS 8/150 SINGLE WITH UNIONS

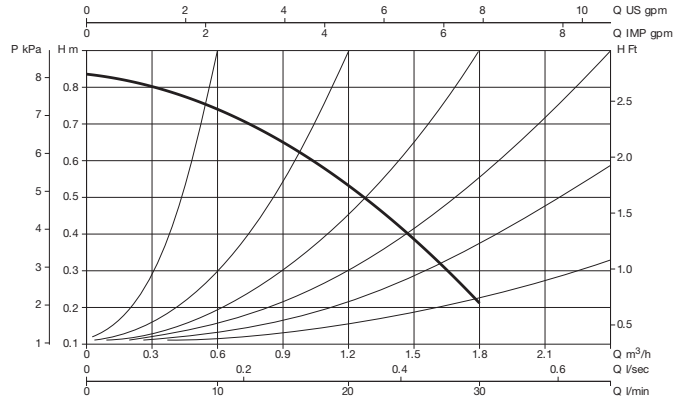
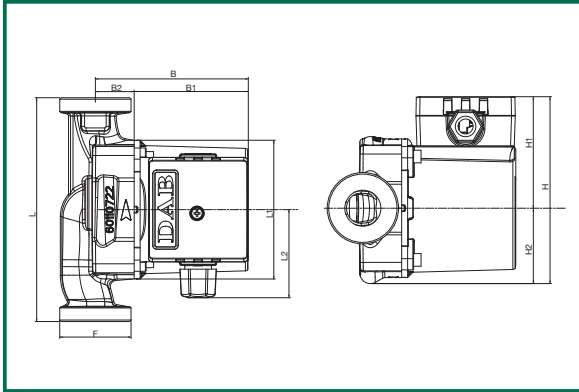
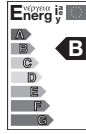

L	L1	L2	B	B1	B2	H	H1	H2	F	PACK DIMENSIONS			VOLUME m ³	WEIGHT Kg
										L	B	H		
150	98	60	104	78	26	124	75	49	1 1/2" G	134	188	150	0,0038	2,6

MODEL	POWER SUPPLY 50 Hz	CENTRE-DISTANCE mm	UNIONS ON REQUEST	ELECTRICAL DATA					MINIMUM SUCTION PRESSURE
				No. rpm	P1 MAX W	In A	CAPACITOR µF Vc		
VS 8/150	1x230 V ~	150	BRASS: 1/2" F - 3/4" F - 1" F COPPER: Ø 22 - Ø 28	1340	22	0,14	1,5	450	t° +90°C m.c.a. 1,5

VS 16/150 SINGLE WITH UNIONS

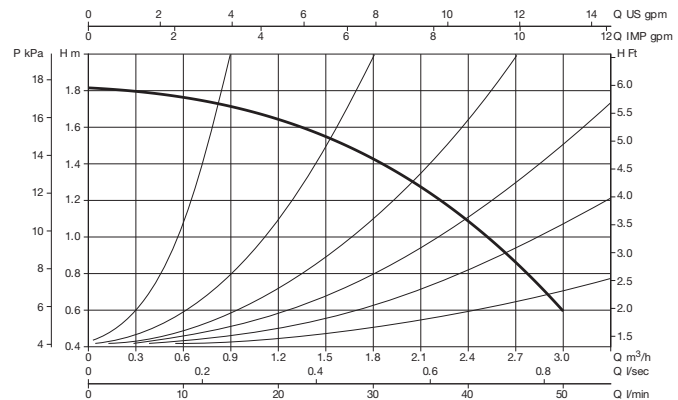
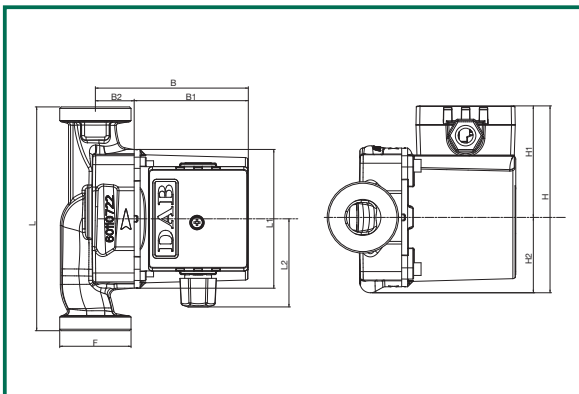
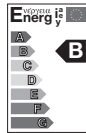

L	L1	L2	B	B1	B2	H	H1	H2	F	PACK DIMENSIONS			VOLUME m ³	WEIGHT Kg
										L	B	H		
150	98	60	104	78	26	124	75	49	1 1/2" G	134	188	150	0,0038	2,6

MODEL	POWER SUPPLY 50 Hz	CENTRE-DISTANCE mm	UNIONS ON REQUEST	ELECTRICAL DATA					MINIMUM SUCTION PRESSURE
				No. rpm	P1 MAX W	In A	CAPACITOR µF Vc		
VS 16/150	1x230 V ~	150	BRASS: 1/2" F - 3/4" F - 1" F COPPER: Ø 22 - Ø 28	2784	41	0,19	1,5	450	t° +90°C m.c.a. 1,5

The performance curves are based on kinematic viscosity values = 1 mm²/s and density equivalent to 1000 kg/m³. Tolerance of curves to ISO 9906.

CIRCULATORS FOR DOMESTIC HOT WATER SYSTEMS

Liquid temperature range: from -10°C to +85°C
 Maximum working pressure: 10 bar (1000 kPa)

VS 35/150 SINGLE WITH UNIONS

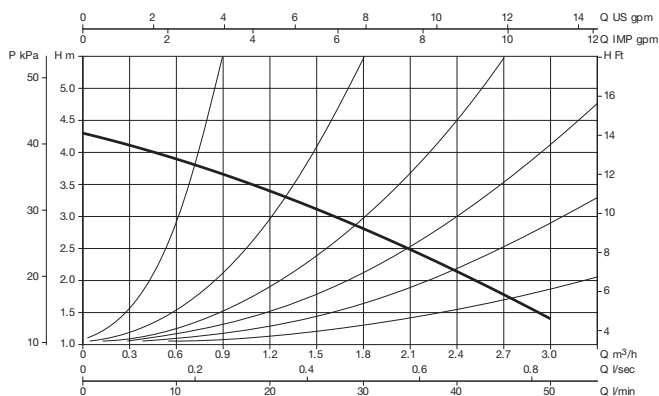
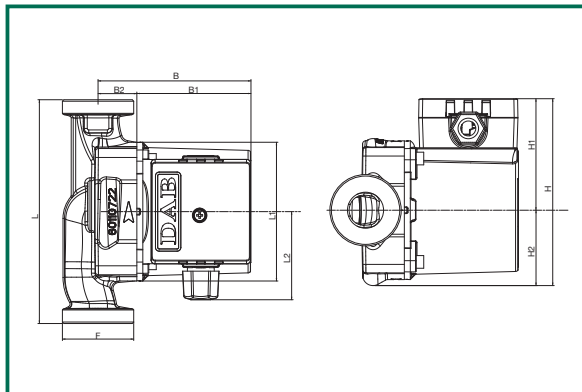
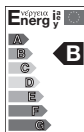

L	L1	L2	B	B1	B2	H	H1	H2	F	PACK DIMENSIONS			VOLUME	WEIGHT
										L	B	H	m ³	Kg
150	98	60	104	78	26	124	75	49	1 1/2" G	134	188	150	0,0038	2,6

MODEL	POWER SUPPLY 50 Hz	CENTRE-DISTANCE mm	UNIONS ON REQUEST	ELECTRICAL DATA					MINIMUM SUCTION PRESSURE
				No. rpm	P1 MAX W	In A	CAPACITOR		
				μF	Vc				
VS 35/150	1x230 V ~	150	BRASS: 1/2" F - 3/4" F - 1" F COPPER: Ø 22 - Ø 28	2470	55	0,24	1,7	450	t° +90°C m.c.a. 1,5

VS 65/150 SINGLE WITH UNIONS

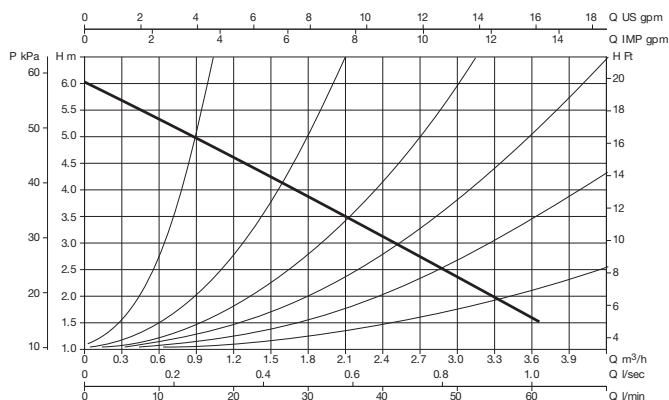
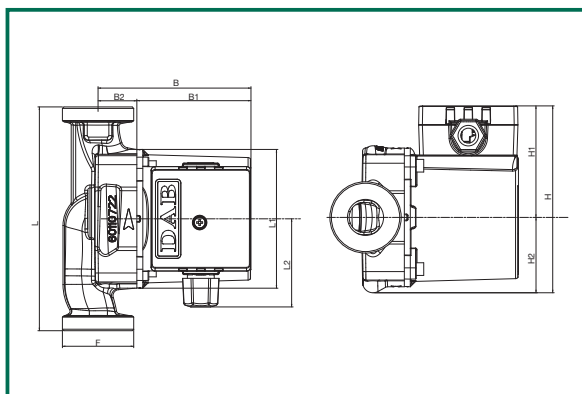
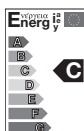

L	L1	L2	B	B1	B2	H	H1	H2	F	PACK DIMENSIONS			VOLUME	WEIGHT
										L	B	H	m ³	Kg
150	98	60	104	78	26	124	75	49	1 1/2" G	134	188	150	0,0038	2,6

MODEL	POWER SUPPLY 50 Hz	CENTRE-DISTANCE mm	UNIONS ON REQUEST	ELECTRICAL DATA					MINIMUM SUCTION PRESSURE
				No. rpm	P1 MAX W	In A	CAPACITOR		
				μF	Vc				
VS 65/150	1x230 V ~	150	BRASS: 1/2" F - 3/4" F - 1" F COPPER: Ø 22 - Ø 28	2317	77	0,34	2	450	t° +90°C m.c.a. 1,5