



Construction

Horizontal multi-stage close coupled pumps in **chrome-nickel stainless steel**.

Compact and robust construction, without protruding flange and with single-piece lantern bracket and base.

Single-piece barrel casing, with front suction port above pumps axis and radial delivery at top.

Filling and draining plugs on the middle of the pump, accessible from any side (like the terminal box).

Applications

For water supply.

For clean liquids, without abrasives, which are non-aggressive for stainless steel (with suitable seal materials, on request).

Universal pump, for domestic use, for civil and industrial applications, for garden use and irrigation.

Operating conditions

Liquid temperature from - 15 °C to + 110 °C.

Ambient temperature up to 40 °C.

Maximum permissible pressure in the pump casing: 8 bar.

Continuous duty.

Motor

2-pole induction motor, 50 Hz (n = 2800 rpm).

MXH: three-phase 230/400 V ± 10%.

MXHM: single-phase 230 V ± 10%, with thermal protector.

Capacitor inside the terminal box.

Insulation class F.

Protection IP 54.

Constructed in accordance with: IEC 60034;

IEC 60038;

IEC 60335-1, EN 60335-1;

IEC 60335-2-41, EN 60335-2-41;

Materials

Component	Material
Pump casing	Chrome-nickel steel 1.4301 EN 10088 (AISI 304)
Stage casing	Chrome-nickel steel 1.4301 EN 10088 (AISI 304)
Wear ring	PTFE
Impeller	Chrome-nickel steel 1.4301 EN 10088 (AISI 304)
Casing cover	Chrome-nickel steel 1.4301 EN 10088 (AISI 304)
Spacer sleeve	Chrome-nickel steel 1.4301 EN 10088 (AISI 304)
Pump shaft	Chrome-nickel steel 1.4305 EN 10088 (AISI 303)
Plug	Chrome-nickel steel 1.4305 EN 10088 (AISI 303)
Mechanical seal with seat according to ISO 3069	Ceramic alumina, carbon, EPDM (Other materials on request)

Special features on request

- Other voltages.
- Frequency 60 Hz (as per 60 Hz data sheet).
- Protection IP 55.
- Special mechanical seal
- Pump casing seal rings in FPM.
- Higher or lower liquid or ambient temperatures.

Coverage chart n ≈ 2800 rpm

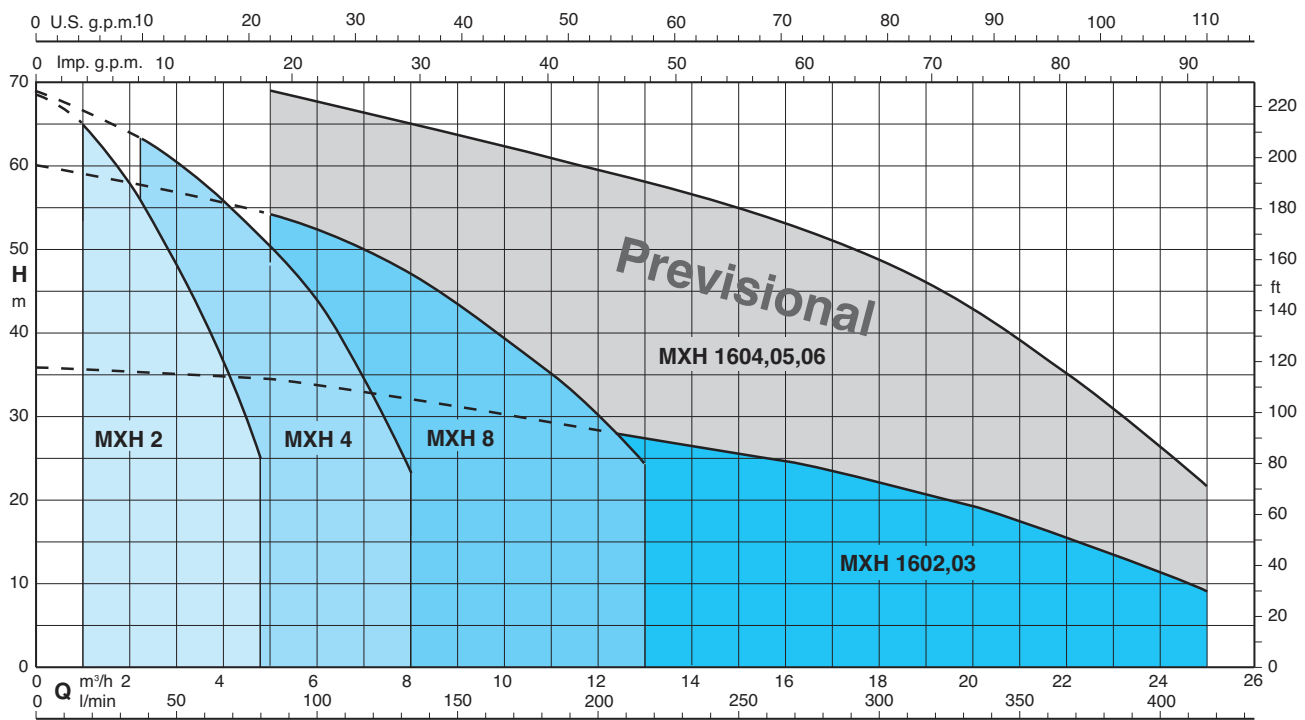

Performance n ≈ 2800 rpm

	3 ~ 230 V 400 V		1 ~ 230 V		P ₁		P ₂		Q										
	A	A	A	kW	kW	HP	m ³ /h	0		1	1,5	2	2,5	3	3,5	4	4,25	4,8	
MXH 202E	1,7	1	MXHM 202E	2,3	0,5	0,33	0,45	H m	0	16,6	25	33,3	41,6	50	58,3	66,6	70,8	80	
MXH 203E	2,4	1,4	MXHM 203E	3	0,65	0,45	0,6		22	20,5	19,4	18	16,4	14,2	12	9,9	8,7	5,5	
MXH 204/A	2,8	1,6	MXHM 204/A	4,2	0,9	0,55	0,75		33	31	29	27	24,5	21,7	18,6	15,5	13,8	9	
MXH 205/A	3,5	2	MXHM 205/A	5,4	1,2	0,75	1		45	42,5	40,4	37,5	34,5	30,8	26,7	22,4	20,1	14,8	
MXH 206/A	4,7	2,7	MXHM 206	7,4	1,5	1,1	1,5		57	53,5	50,5	47,5	43,5	39	34	28,5	25,8	19	
									68,5	65	61,5	58	53,5	48	43	36,5	33,5	25	

	3 ~ 230 V 400 V		1 ~ 230 V		P ₁		P ₂		Q										
	A	A	A	kW	kW	HP	m ³ /h	0		2,25	3	3,5	4	4,5	5	6	7	8	
MXH 402E	2,4	1,4	MXHM 402E	3	0,65	0,45	0,6	H m	0	37,5	50	58,3	66,6	75	83,3	100	116	133	
MXH 403/A	2,8	1,6	MXHM 403/A	4,2	0,9	0,55	0,75		22,5	20	19	18,5	17,5	16	15	12,5	9,5	6	
MXH 404/A	3,5	2	MXHM 404/A	5,4	1,2	0,75	1		33	30	29	27,5	26	24,5	23	19,5	15	9,5	
MXH 405/A	4,7	2,7	MXHM 405	7,4	1,5	1,1	1,5		44,5	40,5	38	36,5	35	33	31	26	20	12,5	
MXH 406	6,4	3,7	MXHM 406	9,2	2	1,5	2		56,5	52	50	47,5	45,5	43	40	33,5	26	16,5	
									68,5	63	60	58	56	53,5	51	44	35	23	

	3 ~ 230 V 400 V		1 ~ 230 V		P ₁		P ₂		Q										
	A	A	A	kW	kW	HP	m ³ /h	0		5	6	7	8	9	10	11	12	13	
MXH 802/A	3,5	2	MXHM 802/A	5,4	1,2	0,75	1	H m	0	83,3	100	116	133	150	166	183	200	216	
MXH 803	5	2,9	MXHM 803	7,4	1,5	1,1	1,5		22,5	20,5	20	19	18	16,5	15	13	11	8,5	
MXH 804	6,4	3,7	MXHM 804	9,2	2	1,5	2		36	32	30,5	29	27,5	25,5	23	20	17	14	
MXH 805	7,5	4,3							48	42,5	41	39	37	34,5	32	28	24	19,5	
									60	54	52	49,5	47	43,5	39,5	35	29,5	24	

	3 ~ 230 V 400 V		P ₂		Q												
	A	A	kW	HP		m ³ /h	0	5	8	11	14	16	18	20	22	25	
MXH 1602	6,4	3,7	1,5	2	H m	0	83,3	133	183	233	266	300	333	366	416		
MXH 1603	7,5	4,3				24	23	21,7	20,5	18,8	17,5	15,8	14	11,5	6,5		
MXH 1604	11,5	6,6				36	34	31,8	29,5	26,8	24,8	22,4	19,2	15,3	8,8		
MXH 1605		9,6				48	46,5	44,5	41,5	38	36	33	29	23	14		
MXH 1606		9,6				4	5,5	60	57,5	55	51,5	48	45	42	37,5	31,5	19
								71	68	65	61	56	53	49	44	36	22

P₁ Max. power input.

P₂ Rated motor power output.

Test results with clean cold water, without gas content.

Tolerances according to ISO 9906, annex A.

+ 0,5 m security margin on NPSH-value is necessary.

Dimensions and weights

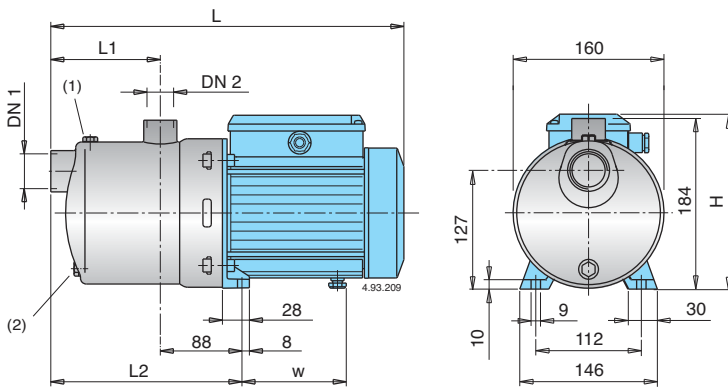

TYPE	DN1 ISO 228	DN2 ISO 228	mm						kg	
			L	L1	L2	H	w	MXH	MXHM	
MXH 202E - MXHM 202E	G 1 1/4	G 1	331	94	182	176	98,5	6,8	6,9	
MXH 203E - MXHM 203E	G 1 1/4	G 1	331	94	182	176	98,5	7,6	7,7	
MXH 204/A - MXHM 204/A	G 1 1/4	G 1	381	118	206	193	112	10	11	
MXH 205/A - MXHM 205/A	G 1 1/4	G 1	405	142	230	193	112	11,5	12,5	
MXH 206/A	G 1 1/4	G 1	429	166	254	193	112	13,5	-	
MXH 402E - MXHM 402E	G 1 1/4	G 1	331	94	182	176	98,5	7,6	7,7	
MXH 403/A - MXHM 403/A	G 1 1/4	G 1	357	94	182	193	112	9,3	10,3	
MXH 404/A - MXHM 404/A	G 1 1/4	G 1	381	118	206	193	112	10,8	11,8	
MXH 405/A	G 1 1/4	G 1	405	142	230	193	112	13	-	
MXH 802/A - MXHM 802/A	G 1 1/2	G 1	381	118	206	193	112	10,6	11,6	

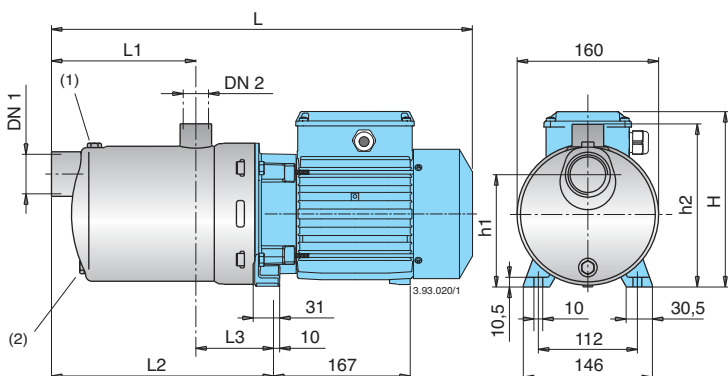

TYPE	DN1 ISO 228	DN2 ISO 228	mm						kg		
			L	L1	L2	L3	H	h1	h2	MXH	MXHM
MXHM 206	G 1 1/4	G 1	500	166	254	88	210	127	184	-	18,6
MXHM 405	G 1 1/4	G 1	476	142	230	88	210	127	184	-	18
MXH 406 - MXHM 406	G 1 1/4	G 1	500	166	254	88	210	127	184	19,5	20,5
MXH 803 - MXHM 803	G 1 1/2	G 1	452	118	206	88	10	127	184	15,8	16,9
MXH 804 - MXHM 804	G 1 1/2	G 1	482	148	236	88	210	127	184	18,2	19,2
MXH 805	G 1 1/2	G 1	512	178	266	88	210	127	184	19	-
MXH 1602	G 2	G 1 1/2	476	128	230	101	210	117	187	18,2	-
MXH 1603	G 2	G 1 1/2	476	128	230	101	210	117	187	18,4	-
MXH 1604	G 2	G 1 1/2	687	166	279	113	225	132	202		
MXH 1605	G 2	G 1 1/2	687	203	316	113	225	132	202		
MXH 1606	G 2	G 1 1/2	687	241	354	113	225	132	202		

(1) Filling (2) Draining

Characteristic curves $n \approx 2800$ rpm

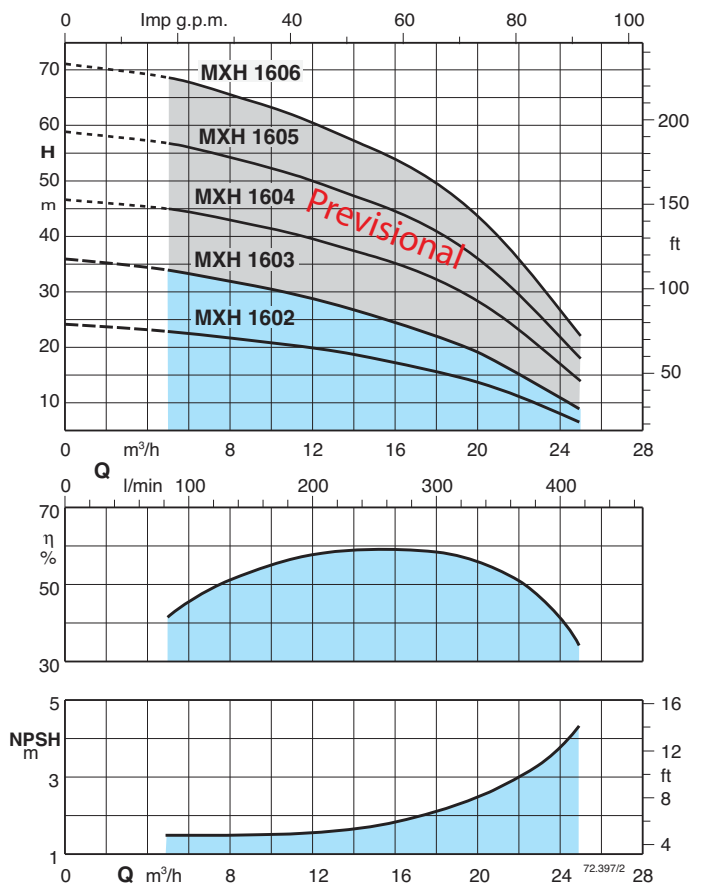
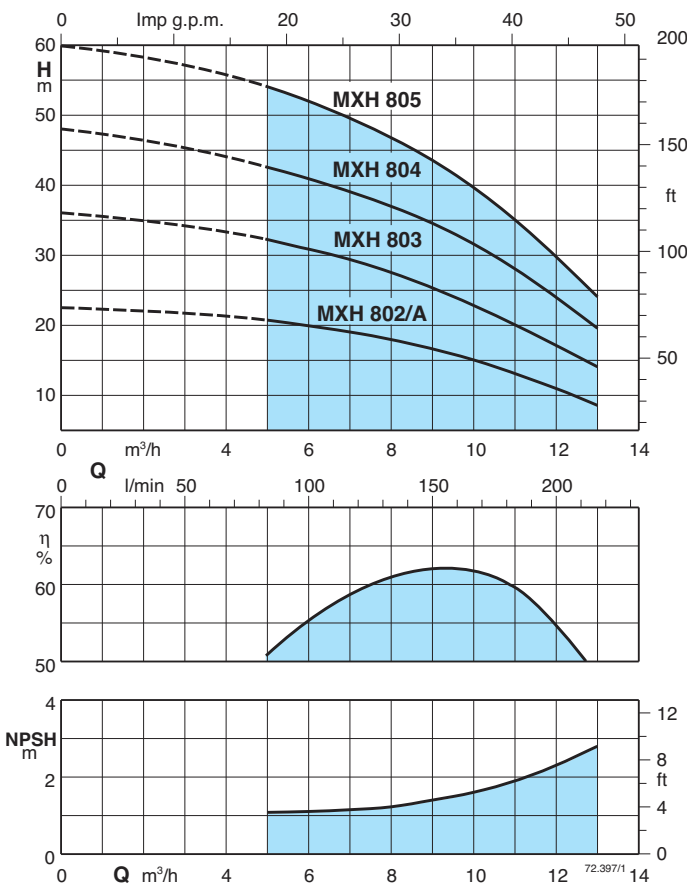
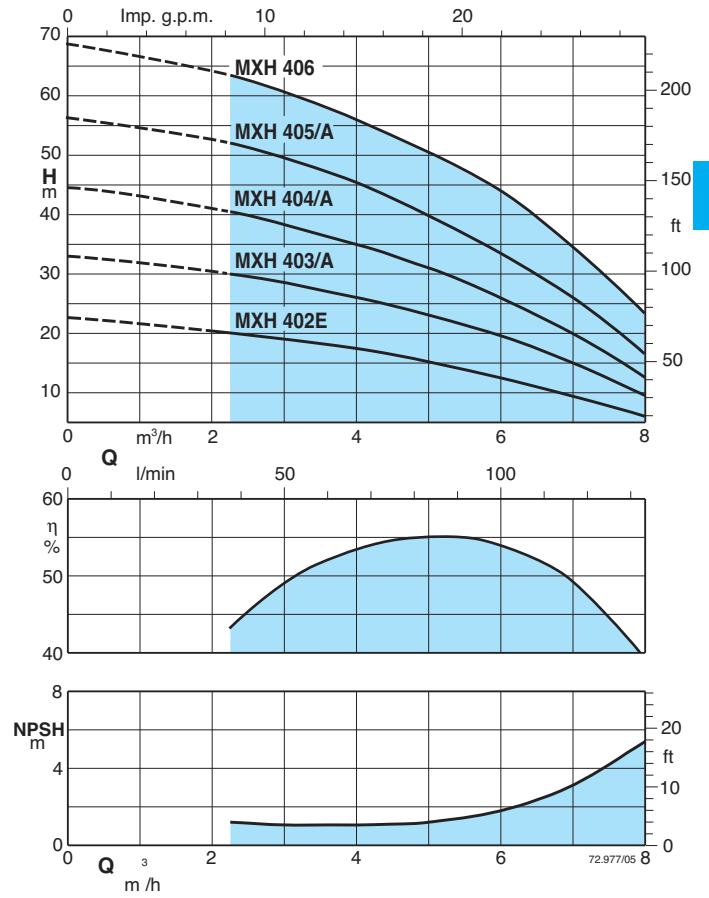
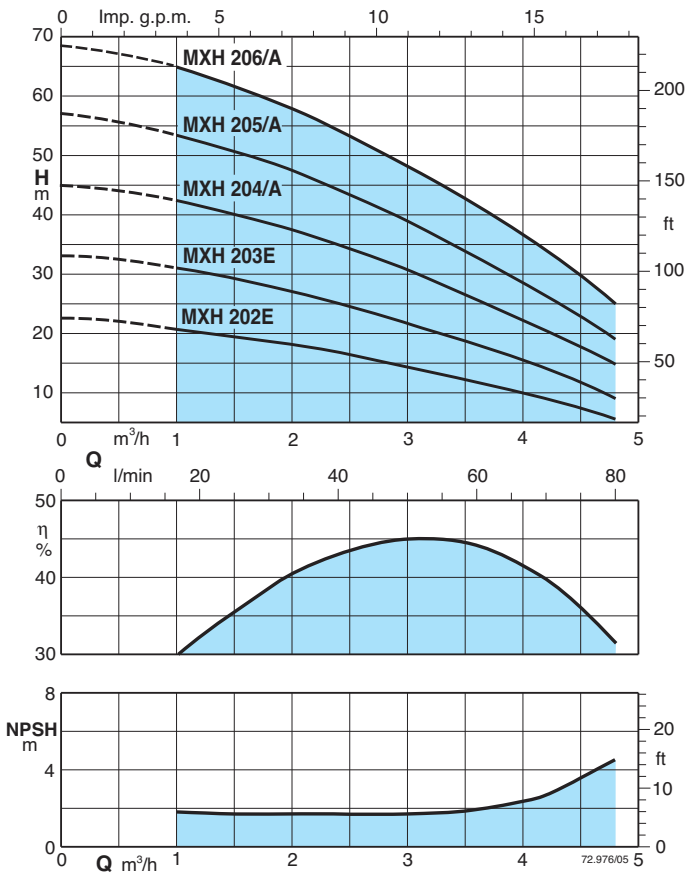

Features

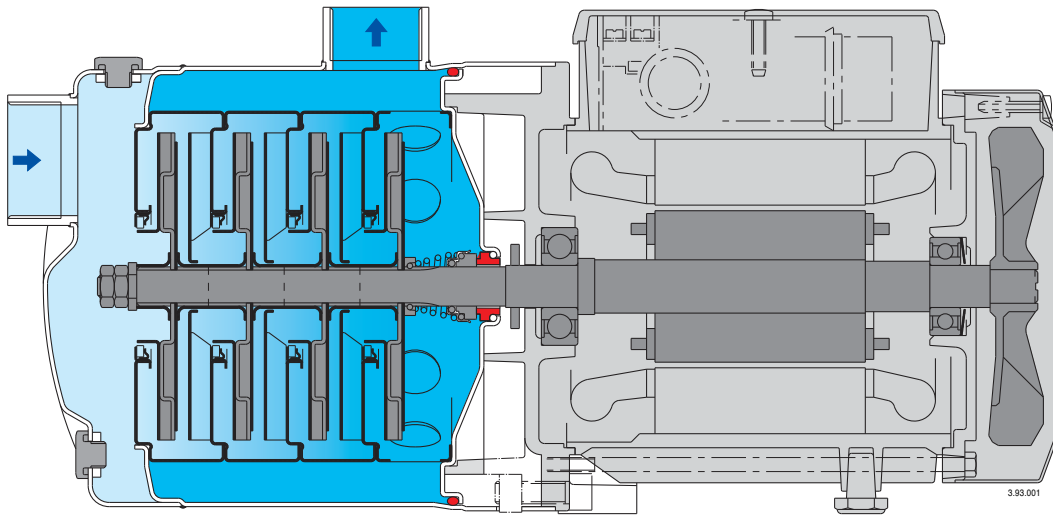

Extra safety

against running dry, with the suction port above pump axis.

Reliable

All hydraulic parts in contact with the pumped liquid are of stainless steel.
For liquids from -15 °C to 110 °C.

Robust

Single-piece, thick barrel casing.

Compact

Single-piece lantern bracket and base.
Without protruding flange.

Greater protection

against leakage, with the pump casing cover separated from the motor shield.
Possibility of inspecting the seal through the side apertures between the two walls.
Greater protection against water entering the motor from outside provided by an extension of the pump casing around the lantern bracket.



Construction

Horizontal multi-stage close coupled pumps in **chrome-nickel-molybdenum stainless steel AISI 316L**. Compact and robust construction, without protruding flange and with single-piece lantern bracket and base. Single-piece barrel casing, with front suction port above pumps axis and radial delivery at top. Filling and draining plugs on the middle of the pump, accessible from any side (like the terminal box).

Applications

For water supply. For clean liquids, without abrasives, which are non-aggressive for stainless steel (with suitable seal materials, on request). Universal pump, for domestic use, for civil and industrial applications, for garden use and irrigation.

Operating conditions

Liquid temperature from - 15 °C to + 110 °C. Ambient temperature up to 40 °C. Maximum permissible pressure in the pump casing: 8 bar. Continuous duty.

Motor

2-pole induction motor, 50 Hz (n = 2800 rpm).
MXHL: three-phase 230/400 V ± 10%.
MXHLM: single-phase 230 V ± 10%, with thermal protector. Capacitor inside the terminal box.

Insulation class F.
 Protection IP 54.

Constructed in accordance with: IEC 60034; IEC 60038; IEC 60335-1, EN 60335-1; IEC 60335-2-41, EN 60335-2-41;

Materials

Component	Material
Pump casing	Cr-Ni-Mo steel 1.4404 EN 10088 (AISI 316L)
Stage casing	Cr-Ni-Mo steel 1.4404 EN 10088 (AISI 316L)
Wear ring	PTFE
Impeller	Cr-Ni-Mo steel 1.4404 EN 10088 (AISI 316L)
Casing cover	Cr-Ni-Mo steel 1.4404 EN 10088 (AISI 316L)
Spacer sleeve	Cr-Ni-Mo steel 1.4404 EN 10088 (AISI 316L)
Pump shaft	Cr-Ni-Mo steel 1.4404 EN 10088 (AISI 316L)
Plug	Cr-Ni-Mo steel 1.4404 EN 10088 (AISI 316L)
Mechanical seal with seat according to ISO 3069	Ceramic alumina, carbon, EPDM (Other materials on request)

Special features on request

- Other voltages.
- Frequency 60 Hz (as per 60 Hz data sheet).
- Protection IP 55.
- Special mechanical seal
- Pump casing seal rings in FPM.
- Higher or lower liquid or ambient temperatures.

Coverage chart n ≈ 2800 rpm

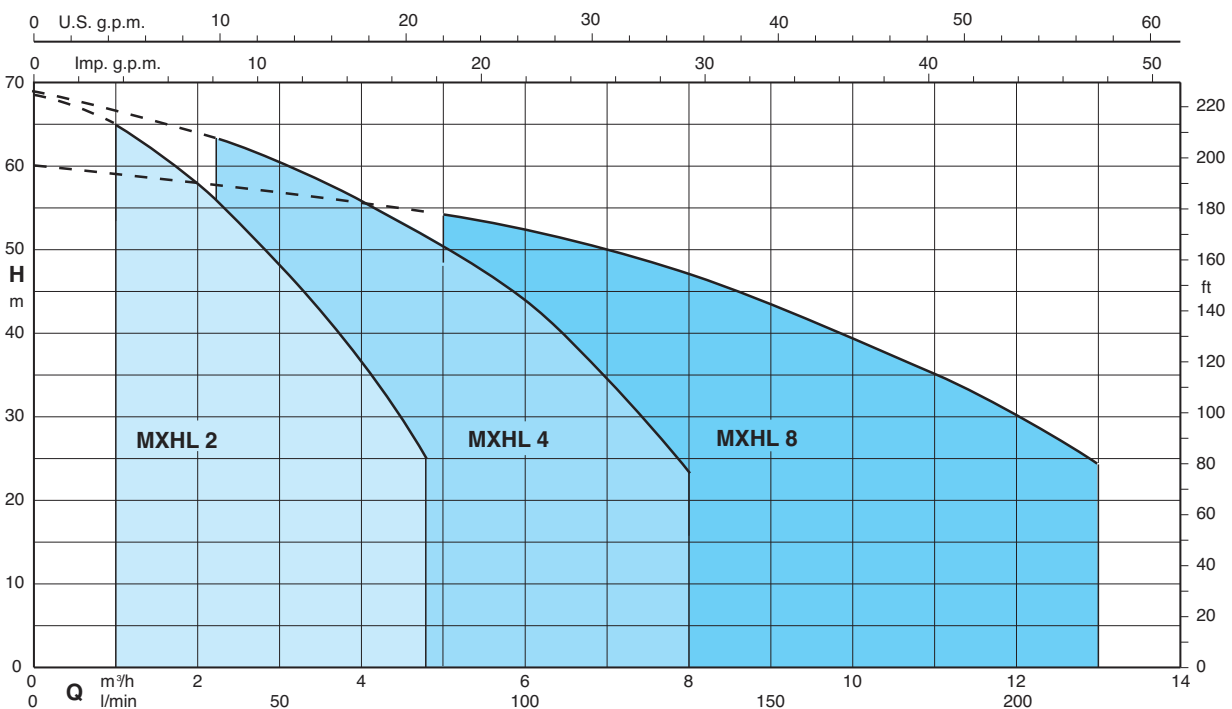

Performance n ≈ 2800 rpm

	3 ~ 230 V 400 V		1 ~ 230 V		P ₁		P ₂		Q										
	A	A	A	kW	kW	HP	m ³ /h	l/min		0	1	1,5	2	2,5	3	3,5	4	4,25	4,8
MXHL 202E	1,7	1	MXHLM 202E	2,3	0,5	0,33	0,45	H m	22	20,5	19,4	18	16,4	14,2	12	9,9	8,7	5,5	
MXHL 203E	2,4	1,4	MXHLM 203E	3	0,65	0,45	0,6		33	31	29	27	24,5	21,7	18,6	15,5	13,8	9	
MXHL 204/A	2,8	1,6	MXHLM 204/A	4,2	0,9	0,55	0,75		45	42,5	40,4	37,5	34,5	30,8	26,7	22,4	20,1	14,8	
MXHL 205/A	3,5	2	MXHLM 205/A	5,4	1,2	0,75	1		57	53,5	50,5	47,5	43,5	39	34	28,5	25,8	19	
MXHL 206/A	4,7	2,7	MXHLM 206	7,4	1,5	1,1	1,5		68,5	65	61,5	58	53,5	48	43	36,5	33,5	25	

	3 ~ 230 V 400 V		1 ~ 230 V		P ₁		P ₂		Q										
	A	A	A	kW	kW	HP	m ³ /h	l/min		0	2,25	3	3,5	4	4,5	5	6	7	8
MXHL 402E	2,4	1,4	MXHLM 402E	3	0,65	0,45	0,6	H m	22,5	20	19	18,5	17,5	16	15	12,5	9,5	6	
MXHL 403/A	2,8	1,6	MXHLM 403/A	4,2	0,9	0,55	0,75		33	30	29	27,5	26	24,5	23	19,5	15	9,5	
MXHL 404/A	3,5	2	MXHLM 404/A	5,4	1,2	0,75	1		44,5	40,5	38	36,5	35	33	31	26	20	12,5	
MXHL 405/A	4,7	2,7	MXHLM 405	7,4	1,5	1,1	1,5		56,5	52	50	47,5	45,5	43	40	33,5	26	16,5	
MXHL 406	6,4	3,7	MXHLM 406	9,2	2	1,5	2		68,5	63	60	58	56	53,5	51	44	35	23	

	3 ~ 230 V 400 V		1 ~ 230 V		P ₁		P ₂		Q													
	A	A	A	kW	kW	HP	m ³ /h	l/min		0	5	6	7	8	9	10	11	12	13			
MXHL 802/A	3,5	2	MXHLM 802/A	5,4	1,2	0,75	1	H m	22,5	20,5	20	19	18	16,5	15	13	11	8,5				
MXHL 803	5	2,9	MXHLM 803	7,4	1,5	1,1	1,5		36	32	30,5	29	27,5	25,5	23	20	17	14				
MXHL 804	6,4	3,7	MXHLM 804	9,2	2	1,5	2		48	42,5	41	39	37	34,5	32	28	24	19,5				
MXHL 805	7,5	4,3							60	54	52	49,5	47	43,5	39,5	35	29,5	24				

P₁ Max. power input.

P₂ Rated motor power output.

Test results with clean cold water, without gas content.
Tolerances according to ISO 9906, annex A.

+ 0,5 m security margin on NPSH-value is necessary.

Dimensions and weights

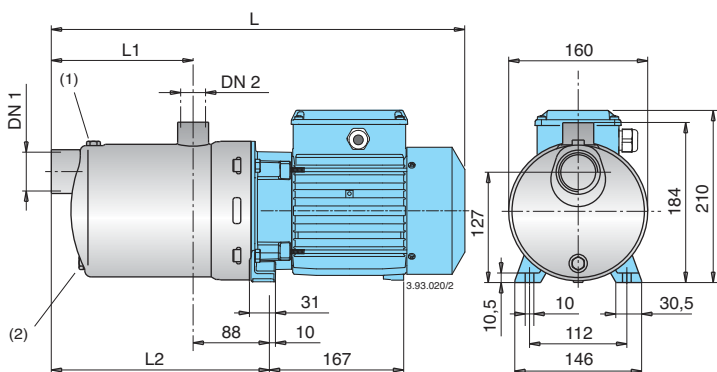
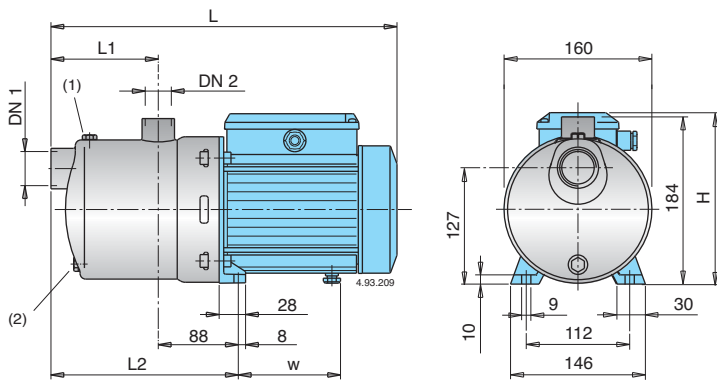

TYPE	DN1	DN2	mm					kg	
			L	L1	L2	H	w	MXHL	MXHLM
MXHL 202E - MXHLM 202E	G 1 1/4	G 1	331	94	182	176	98,5	6,8	6,9
MXHL 203E - MXHLM 203E	G 1 1/4	G 1	331	94	182	176	98,5	7,6	7,7
MXHL 204/A - MXHLM 204/A	G 1 1/4	G 1	381	118	206	193	112	10	11
MXHL 205/A - MXHLM 205/A	G 1 1/4	G 1	405	142	230	193	112	11,5	12,5
MXHL 206/A	G 1 1/4	G 1	429	166	254	193	112	13,5	-
MXHL 402E - MXHLM 402E	G 1 1/4	G 1	331	94	182	176	98,5	7,6	7,7
MXHL 403/A - MXHLM 403/A	G 1 1/4	G 1	357	94	182	193	112	9,3	10,3
MXHL 404/A - MXHLM 404/A	G 1 1/4	G 1	381	118	206	193	112	10,8	11,8
MXHL 405/A	G 1 1/4	G 1	405	142	230	193	112	13	-
MXHL 802/A - MXHLM 802/A	G 1 1/2	G 1	381	118	206	193	112	10,6	11,6

TYPE	DN1	DN2	mm			kg	
			L	L1	L2	MXHL	MXHLM
MXHLM 206	G 1 1/4	G 1	500	166	254	-	18,6
MXHLM 405	G 1 1/4	G 1	476	142	230	-	18
MXHL 406 - MXHLM 406	G 1 1/4	G 1	500	166	254	19,5	20,5
MXHL 803 - MXHLM 803	G 1 1/2	G 1	452	118	206	15,8	16,9
MXHL 804 - MXHLM 804	G 1 1/2	G 1	482	148	236	18,2	19,2
MXHL 805	G 1 1/2	G 1	512	178	266	19	-

(1) Filling (2) Draining

Characteristic curves $n \approx 2800$ rpm

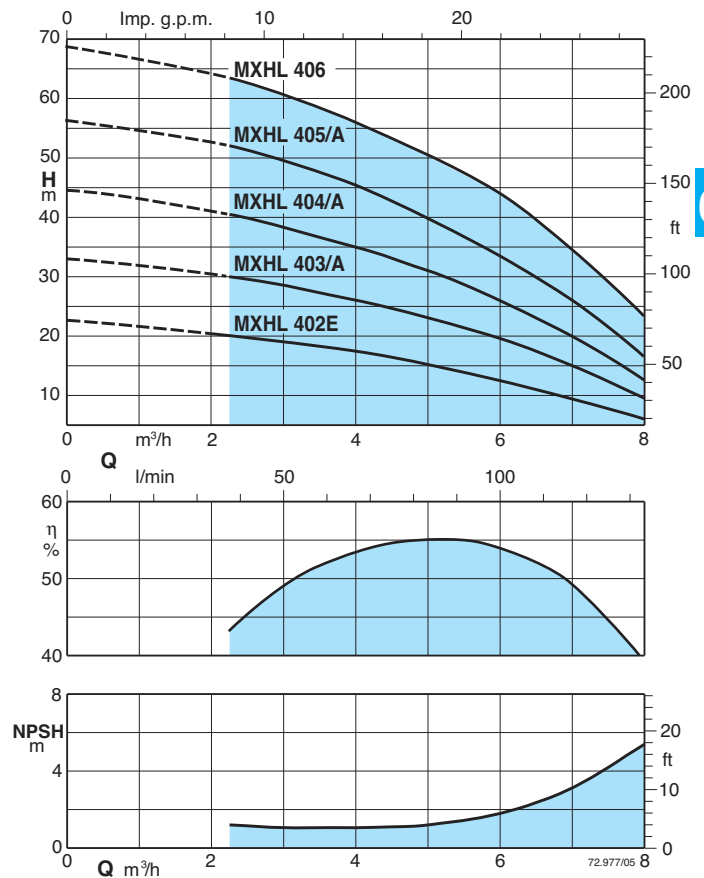
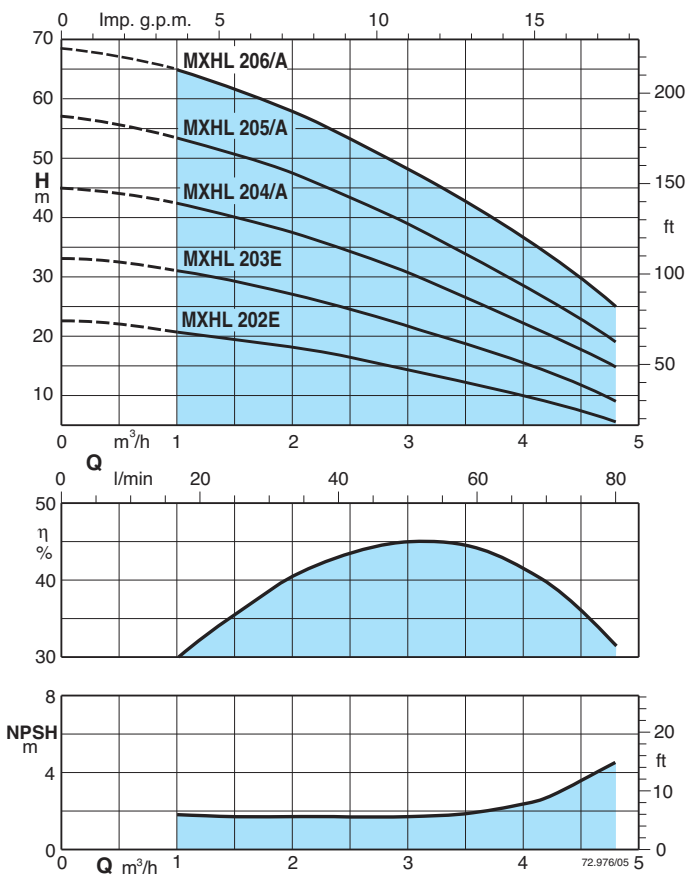

6.1

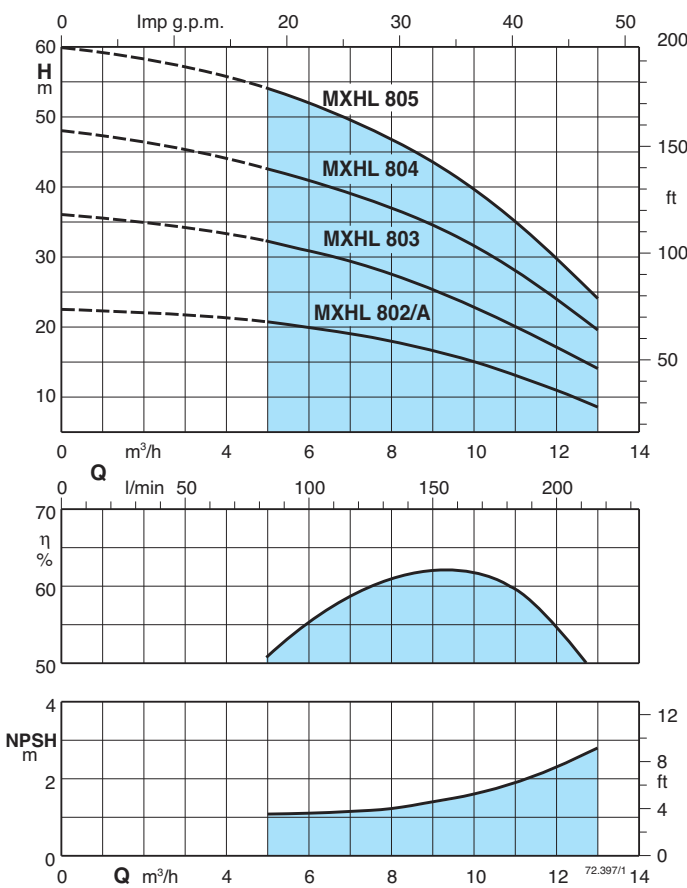

Features

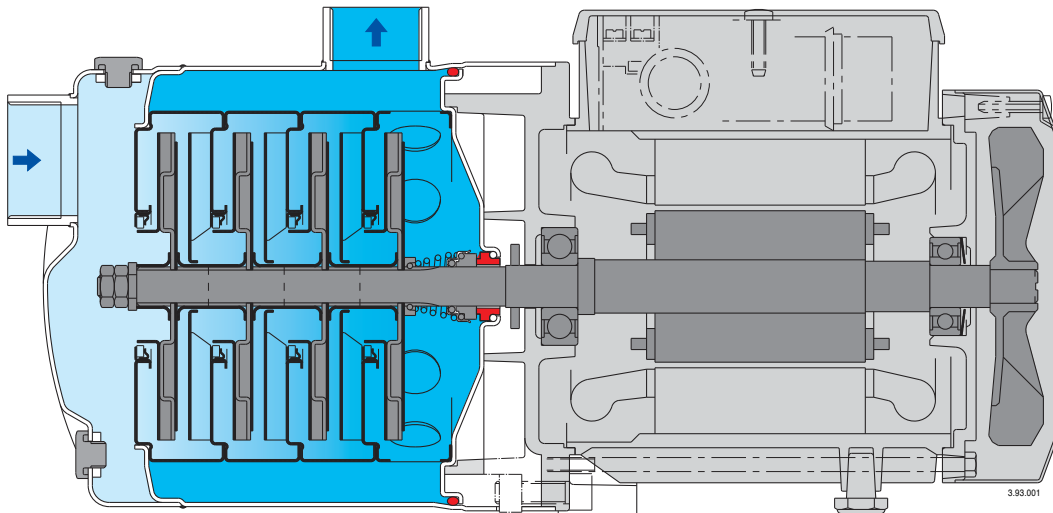

Extra safety

against running dry, with the suction port above pump axis.

Reliable

All hydraulic parts in contact with the pumped liquid are of stainless steel.
For liquids from -15 °C to 110 °C.

Robust

Single-piece, thick barrel casing.

Compact

Single-piece lantern bracket and base.
Without protruding flange.

Greater protection

against leakage, with the pump casing cover separated from the motor shield.
Possibility of inspecting the seal through the side apertures between the two walls.
Greater protection against water entering the motor from outside provided by an extension of the pump casing around the lantern bracket.